



特深專利二段、自吸式高速泵浦系列



泵浦特點: 採渦流式不銹鋼葉輪、壓力大、水量多。離心式設計，噪音低。

適用範圍: 高樓、公寓、住宅、工廠、地下室、學校、工事給水、地下水、山坡地送水、農業灌溉等等。

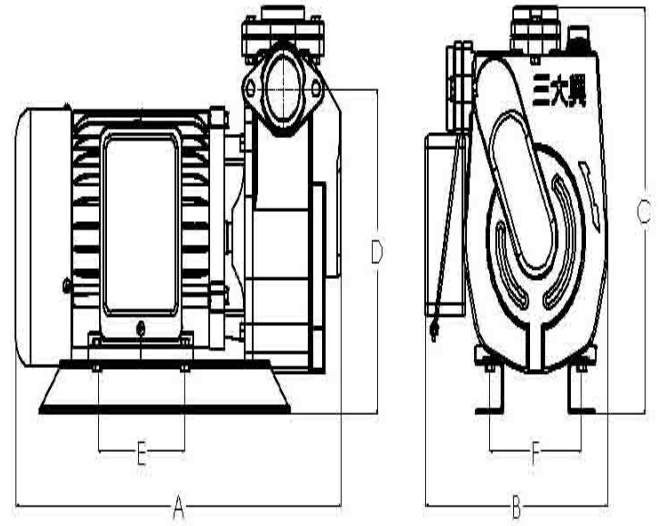
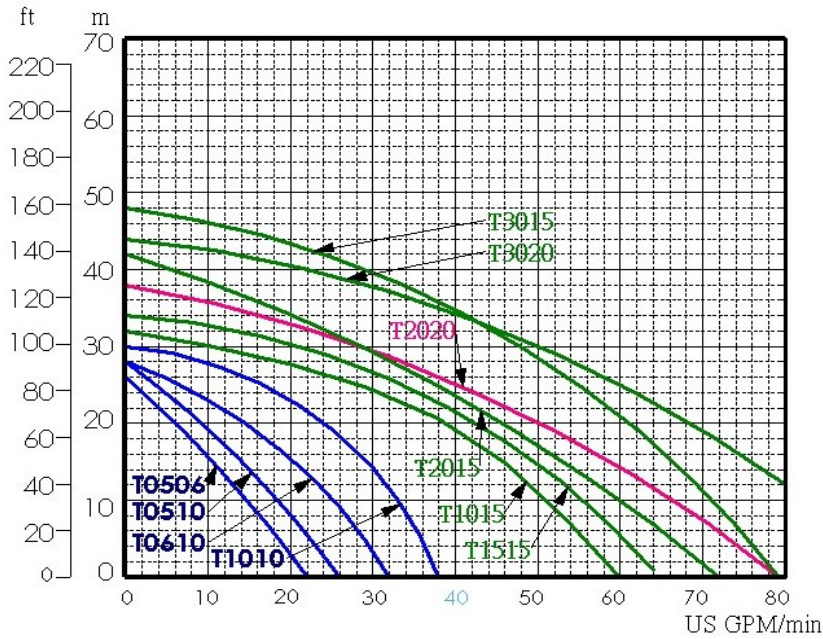

型號	相數	額定電壓	額定輸出	出入口徑	極數	最高揚程	最大水量	重量	尺寸 SIZE					
TYPE	PH	VOLT	H P	Inch	P	M	USG/min	KG	A	B	C	D	E	F
TPS0506	1	110/220	1/2	3/4"	2P	26	26	16	33	21	23	18.5	10.5	10
TPS0510	1	110/220	1/2	1"	2P	29	30	17.5	34	21	23	18.5	11.5	10
TPT0510	3	220/380	1/2	1"	2P	29	30	16	33	21	23	18.5	10.5	10
TPS0610	1	110/220	3/4	1"	2P	33	35	25.5	37.5	24	25	20.5	12.5	12.5
TPS1010	1	110/220	1	1"	2P	36	38	26.5	37.5	26.5	25.5	20.5	10.5	13.5
TPT1010	3	220/380	1	1"	2P	36	38	26.5	37.5	26.5	25.5	20.5	10.5	13.5
TPS1015	1	110/220	1	1 1/2"	2P	34	66	28.5	40	26.5	27.5	22	12.5	13.5
TPT1015	3	220/380	1	1 1/2"	2P	34	66	28.5	40	26.5	27.5	22	12.5	13.5
TPS1515	1	110/220	1.5	1 1/2"	2P	40	66	35	41.5	26.5	29.5	25.5	12.5	13.5
TPS2015	1	110/220	2	1 1/2"	2P	46	72	37.5	44.5	26.5	31.5	25.5	12.5	13.5
TPT2015	3	220/380	2	1 1/2"	2P	46	72	36	42	26.5	31.5	25.5	12.5	13.5
TPS2020	1	110/220	2	2"	2P	38	80	40.5	43	26.5	32.5	25.5	12.5	13.5
TPT2020	3	220/380	2	2"	2P	38	80	39	43	26.5	32.5	25.5	12.5	13.5
TPS3015	1	220	3	1 1/2"	2P	48	80	55	44	30	34.5	28	14	16
TPT3015	3	220/380	3	1 1/2"	2P	48	80	53.5	46	30	34.5	28	14	16
TPS3020	1	220	3	2"	2P	44	90	51.5	44	30	34.5	28	14	16
TPT3020	3	220/380	3	2"	2P	44	90	50	46	30	34.5	28	14	16